

# Lawn Tractors LT150, LT160, LT180

OMM148426 H2

## Replacing Mower Drive Belt (38-Inch and 42C Decks)

**NOTE:** In this procedure the mower deck is removed for easier access.

1. Park machine safely. (See Parking Safely in Safety section.)
2. Allow engine and muffler to cool completely.
3. Remove mower if desired.

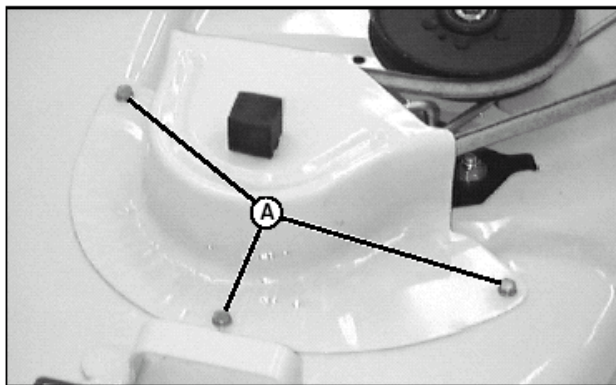

M88485

4. Remove three cap screws (A) or lock nuts (on 42C) and belt shield.
5. On 42C deck, remove wear plate beneath shield.

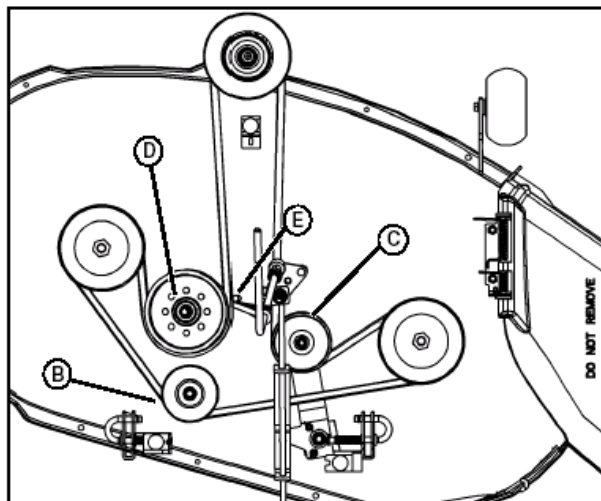

MX11144

6. Loosen rear idler (B) and tensioning sheave (C). On 42C deck, also loosen fixed idler (D).
7. Remove mower belt.
8. Clean top of mower.
9. Install new belt on mower as shown above.
10. Tighten rear idler and tensioning sheave.
11. On 42C deck, install wear plate and tighten fixed idler.

**IMPORTANT:** Avoid damage! Make sure locator on belt guide (E) is aligned with hole on fixed idler (D) mounting bracket before tightening.

12. Install belt shield and fasten with three cap screws or lock nuts (on 42C).

13. Install mower deck and adjust mower engagement rod, if necessary.

## Replacing Mower Drive Belt (48C Deck)

1. Park machine safely. (See Parking Safely in Safety section.)
2. Allow engine and muffler to cool completely.
3. Remove mower if desired.

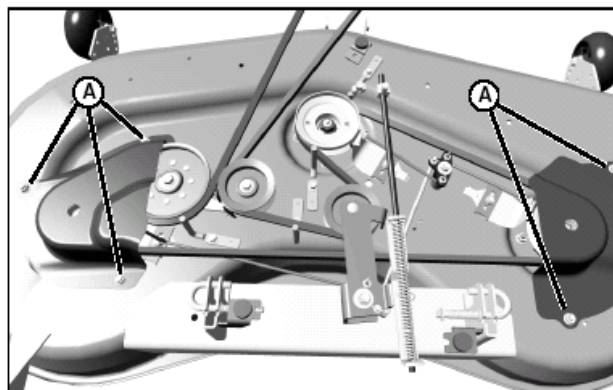

MX16506

4. Remove flange nuts (A) and left and right belt shields.

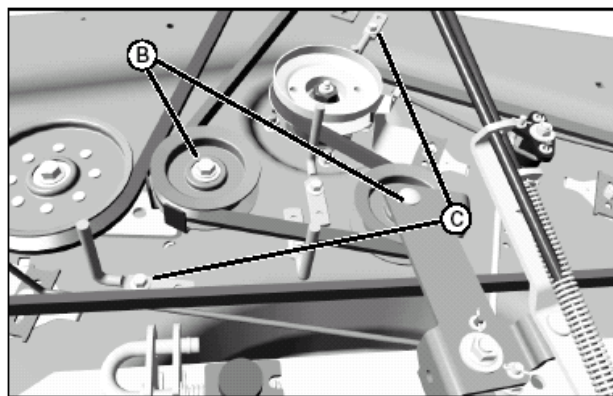

MX16508

5. Loosen idlers (B) and belt guides (C).
6. Remove mower belt.
7. Clean top of mower.
8. Install new belt on mower as shown above.
9. Align belt guide locators with holes in deck and tighten belt guides (C).
10. Align notch in belt guide on fixed idler with locator on idler bracket and tighten idlers (B).
11. Install belt shields and fasten with flange nuts.
12. Install mower deck and adjust mower engagement rod, if necessary.

## Replacing Mower Drive Belt (Freedom 42 Deck)

1. Park machine safely. (See Parking Safely in Safety section.)
2. Allow engine and muffler to cool completely.
3. Remove mower.

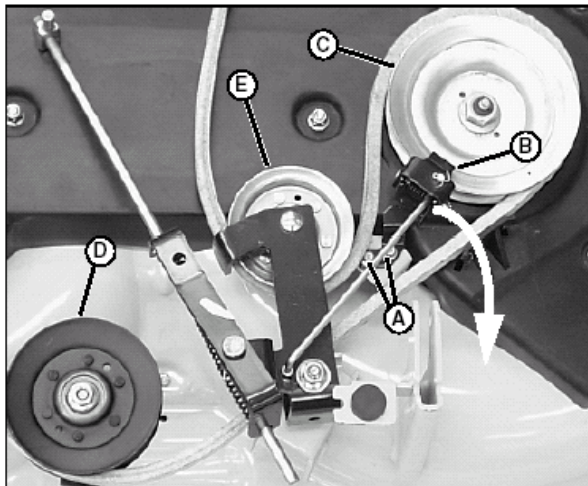

MX5359

4. Remove self-tapping cap screws (A).
5. Move brake assembly (B) away from sheave (C) and drive belt.
6. Loosen idler (D) and tensioning idler (E) just enough to slip belt past the guides.
7. Remove drive belt and clean top of mower.
8. Install new belt on mower deck as shown.
9. Tighten idler (D) and tensioning idler (E).
10. Align brake assembly (B) with right spindle sheave (C) and fasten with self-tapping cap screws (A). Brake pad must seat against top of sheave.
11. Install mower and adjust mower engagement rod, if necessary.